

Errata

This manual may contain references to HP or Hewlett-Packard. Please note that Hewlett-Packard's former test and measurement, semiconductor products and chemical analysis businesses are now part of Agilent Technologies. To reduce potential confusion, the only change to product numbers and names has been in the company name prefix: where a product number/name was HP XXXX the current name/number is now Agilent XXXX. For example, model number HP8648 is now model number Agilent 8648.

Ce manuel peut contenir des références à <<HP>> ou <<Hewlett-Packard.>> Veuillez noter que les produits de test et mesure, de semi-conducteur et d'analyse chimique qui avaient fait partie de la société Hewlett-Packard sont maintenant une partie de la société Agilent Technologies. Pour réduire la confusion potentielle, le seul changement aux noms de référence a été dans le préfixe de nom de société : là où un nom de référence était HP XXXX, le nouveau nom de référence est maintenant Agilent XXXX. Par exemple, le HP 8648 s'appelle maintenant Agilent 8648.

Diese Gebrauchsanweisung kann Bezug nehmen auf die Namen HP oder Hewlett-Packard. Bitte beachten Sie, dass ehemalige Betriebsbereiche von Hewlett-Packard wie HP-Halbleiterprodukte, HP-chemische Analysen oder HP-Test- und Messwesen nun zu der Firma Agilent Technology gehören. Um Verwirrung zu vermeiden wurde lediglich bei Produktname und - Nummer der vor laufende Firmenname geändert: Produkte mit dem Namen/Nummer HP XXXX lauten nun mehr Agilent XXXX. Z.B, das Modell HP 8648 heißt nun Agilent 8648.

Questo manuale potrebbe contenere riferimenti ad HP o Hewlett-Packard. Si noti che le attività precedentemente gestite da Hewlett-Packard nel campo di Test & Misura, Semiconduttori, ed Analisi Chimica sono ora diventate parte di Agilent Technologies. Al fine di ridurre il rischio di confusione, l'unica modifica effettuata sui numeri di prodotto e sui nomi ha riguardato il prefisso con il nome dell'azienda : dove precedentemente compariva "HP XXXX" compare ora "Agilent XXXX". Ad esempio: il modello HP8648 è ora indicato come Agilent 8648.

Este manual puede hacer referencias a HP o Hewlett Packard. Las organizaciones de Prueba y Medición (Test and Measurement), Semiconductores (Semiconductor Products) y Análisis Químico (Chemical Analysis) que pertenecían a Hewlett Packard, ahora forman parte de Agilent Technologies. Para reducir una potencial confusión, el único cambio en el número de producto y nombre, es el prefijo de la compañía: Si el producto solía ser HP XXXX, ahora pasa a ser Agilent XXXX. Por ejemplo, el modelo HP8648 es ahora Agilent 8648.

这个手册里面可能含有惠普公司的资料。请注意惠普公司以前的测试, 半导体产品, 化学分析部门现在属于安捷伦公司。为了减少可能的误解, 产品号码和名字只改变最前面的公司名字。如果一个产品的号码/名字以前是HP XXXX, 现在的号码/名字是安捷伦 XXXX。例如模型号码是惠普8648。现在是模型号码安捷伦8648。

Document Part Number 5971-2668
Printed in the UK September 2004

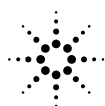

Agilent Technologies

マニュアル・チェンジ

変更

本文中の「HP (YHP)」、または「(横河)ヒューレット・パッカー株式会社」という語句を、「Agilent」、または「アジレント・テクノロジー株式会社」と変更してください。

ヒューレット・パッカー社の電子計測、半導体製品、化学分析ビジネス部門は分離独立し、アジレント・テクノロジー社となりました。

社名変更に伴うお客様の混乱を避けるため、製品番号の接頭部のみ変更しております。

(例: 旧製品名 HP 4294A は、現在 Agilent 4294A として販売いたしております。)

Operation and Service Guide

Agilent E4412A and E4413A

Power Sensors



Agilent Technologies

Part No. E4412-90013

Printed in USA

June 1999

© Copyright 1999-2001 Agilent Technologies, Inc.

Legal

The information contained in this document is subject to change without notice. Agilent Technologies makes no warranty of any kind with regard to this material, including but not limited to, the implied warranties of merchantability and fitness for a particular purpose. Agilent Technologies shall not be liable for errors contained herein or for incidental or consequential damages in connection with the furnishing, performance, or use of this material.

Notice - Hewlett-Packard to Agilent Technologies Transition

This documentation supports a product that previously shipped under the Hewlett-Packard company brand name. The brand name has now been changed to Agilent Technologies. The two products are functionally identical, only our name has changed. The document still includes references to Hewlett-Packard products, some of which have been transitioned to Agilent Technologies.

Safety Information

WARNING:

Warning denotes a hazard. It calls attention to a procedure which, if not correctly performed or adhered to, could result in injury or loss of life. Do not proceed beyond a warning note until the indicated conditions are fully understood and met.

CAUTION:

Caution denotes a hazard. It calls attention to a procedure that, if not correctly performed or adhered to, would result in damage to or destruction of the instrument. Do not proceed beyond a caution sign until the indicated conditions are fully understood and met.

CAUTION:

This product is designed for use in Installation Category II and Pollution Degree 2.

This instrument has been designed and tested in accordance with IEC Publication 348, Safety Requirements for Electronic Measuring Apparatus, and has been supplied in a safe condition. The instruction documentation contains information and warnings which must be followed by the user to ensure safe operation and to maintain the instrument in a safe condition.

“CSA” The CSA mark is a registered trademark of the Canadian Standards Association.

Notice for Germany: Noise Declaration $L_{pA} < 70$ dB am Arbeitsplatz (operator position) normaler Betrieb (normal position) nach DIN 45635 T. 19 (per ISO 7779).

Safety Information

Operation and Service Guide



ss71a

Figure 1

E4412A and E4413A Power Sensors (Formerly ECP-E18A and ECP-E26A, Respectively)

General Information

This operation and service guide contains information about initial inspection, operation, performance tests, troubleshooting and repair of the E4412A and E4413A power sensors.

Warranty

The power sensors are warranted and certified as indicated on the inside cover of this manual.

Instruments Covered by Manual

These instruments have a two-part serial number: the prefix (two letters and the first four numbers), and the suffix (the last four numbers). The two letters identify the country in which the unit was manufactured. The four numbers of the prefix are a code identifying the date of the last major design change incorporated in your Agilent Technologies product. The four-digit suffix is a sequential number and, coupled with the prefix, provides a unique identification for each unit produced. The contents of this manual apply directly to all serial numbers unless otherwise indicated.

Description

The E4412A and E4413A power sensors are diode power sensors. They are intended for measurement of CW microwave power levels in a wide dynamic range from -70 dBm to $+20$ dBm (100 pW to 100 mW). The E4412A measures at frequencies from 10 MHz to 18.0 GHz. The E4413A measures at frequencies from 50 MHz to 26.5 GHz. These are high-speed power sensors, and do not incorporate narrow-bandwidth averaging used in average-power sensors. Signals with digital, pulse, or other forms of amplitude modulation may introduce measurement errors. Multi-tone signals (containing multiple frequency components), or signals with significant harmonic content (> -45 dBc) may introduce measurement errors at high power levels. (Specifications for the power sensors are in Table 1.)

General Information

These power sensors measure CW power, displayed on a compatible power meter in logarithmic (dBm or dB) or linear (Watts or %) measurement units. The E4413A is shipped with a 3.5-mm to Type-N adapter, part number 08485-60005.

NOTE:

The E4412A and E4413A power sensors are compatible **ONLY** with the newer E44XX-Series power meters. They are **NOT** compatible with the earlier 430-Series, E1416A, or 70100A power meters.

CAUTION:

The E4412A and E4413A power sensors are extremely static-sensitive. Do not open the power sensor unless you and the power sensor are at a static-free workstation.

Specifications

The specifications listed in Table 1 are the performance standards or limits against which the power sensor may be tested. These specifications are valid **ONLY** after proper calibration of the power meter. Refer to the *Calibration Procedure Using Agilent E-Series Power Sensors* in the E4418A or the *Agilent E4419A Power Meter User's Guide*.

Table 1 E4412A and E4413A Specifications

	Limits	Comments
Frequency Range	E4412A: 10 MHz to 18 GHz E4413A: 50 MHz to 26.5 GHz	
Power Range	-70 dBm to +20 dBm (100 pW to 100 mW)	
Impedance	50 ohm	nominal
Connector Type	E4412A: Type-N (male) E4413A: 3.5-mm (male)	
Maximum Standing Wave Ratio (SWR) and Reflection Coefficient (Rho)	SWR Rho	Return Loss (dB)
E4412A		
10 MHz to <30 MHz	1.22 0.099	20.08
30 MHz to <2 GHz	1.15 0.070	23.13
2 GHz to <6 GHz	1.17 0.078	22.12
6 GHz to <11 GHz	1.20 0.091	20.82
11 GHz to <18 GHz	1.27 0.119	18.42
E4413A		
50 MHz to <100 MHz	1.21 0.095	20.45
100 MHz to <8 GHz	1.19 0.087	21.23
8 GHz to <18 GHz	1.21 0.095	20.45
18 GHz to 26.5 GHz	1.26 0.115	18.79
Maximum Power	200 mW peak (+23 dBm) 200 mW average (+23 dBm)	
Zero Set	±50 pW	

Operation and Service Guide
General Information

Table 1 E4412A and E4413A Specifications

	Limits		Comments
Power Linearity^{ab}	25 ± 5°C	0 to 55°C	(After calibration at 0 dBm at ambient temperature)
100 pW to 10 mW	±3%	±7%	-70 dBm to +10 dBm
10 mW to 100 mW	±4.5%	±10%	+10 dBm to +20 dBm
Operating Temperature	0 to 55°C		
Net Weight			
E4412A	0.47 kg (1.04 lb)		
E4413A	0.45 kg (1.00 lb)		
Dimensions			
E4412A	Length: 130 mm (5.1 in)		Same for both models Same for both models
E4413A	Length: 102 mm (4.0 in)		
	Width: 38 mm (1.5 in)		
	Height: 30 mm (1.2 in)		

- a. Limits are in percent of power in Watts. See Figure 2 for relative power measurement.
- b. Specifications apply to instruments with serial prefix US3848 and above. For earlier instruments, refer to Appendix A.

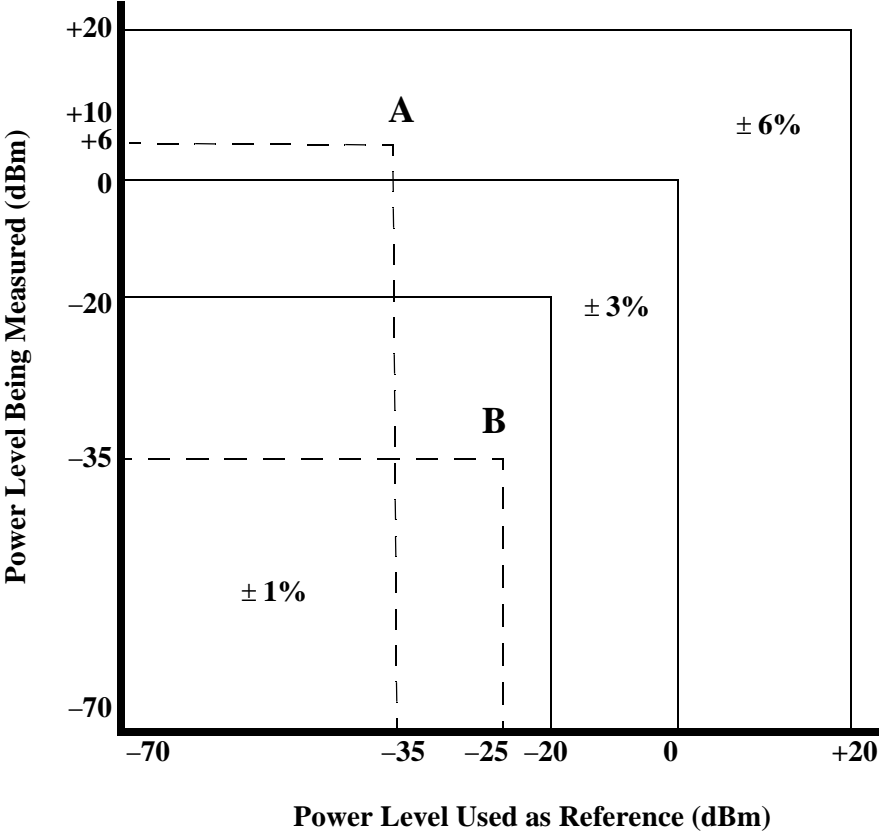

Figure 2

**Relative Mode Power Measurement Linearity
with Power Meter/Sensor at 25° C (Typical)**

The chart in Figure 2 shows the typical uncertainty in making a relative power measurement with the E44XX-Series power meter in the Rel (relative) mode. In a relative measurement, two power levels are compared using a single sensor. The typical measurement uncertainty can be found by drawing a vertical line at the power level used as a reference, and a horizontal line at the power being measured. The region where these two lines intersect shows the typical uncertainty. This assumes that the reference power and the measured power are at the same frequency, and neglects errors due to zero set, zero drift, and noise. It also assumes no change in mismatch when mea-

General Information

asuring the “Power level used as reference” and the “Power level being measured.” This chart illustrates that the best relative power measurement accuracy is obtained when the reference and the measured power levels are equal to, or less than, -20 dBm. Care in choosing the power levels can yield improved measurement accuracy. Example A illustrates a relative gain (amplifier measurement) and example B illustrates a relative loss (insertion loss measurement).

EXAMPLE A (Amplifier Gain Measurement):

Input power (reference) = -35 dBm; power measured = $+6$ dBm, so the relative gain is $+41$ dB. The chart indicates a typical error of $\pm 6\%$, which corresponds to $+0.25$ dB/ -0.27 dB uncertainty in the gain measurement.

EXAMPLE B (Insertion Loss Measurement):

Reference power = -25 dBm; power measured = -35 dBm, for the case of an insertion loss of 10 dB. The chart indicates a typical error of $\pm 1\%$, which corresponds to ± 0.04 dB uncertainty in the measurement.

Calibration Factor (CF) and Reflection Coefficient (Rho)

Calibration factor and reflection coefficient data are given at 1 GHz increments on a data sheet included with the power sensor. This data is unique to each sensor. If you have more than one sensor, match the serial number on the data sheet with the serial number on the power sensor you are using. The CF corrects for the frequency response of the sensor. The power meter automatically reads the CF data stored in the sensor and uses it to make the corrections.

Reflection Coefficient (Rho, or ρ) relates to SWR according to the following formula:

$$\text{SWR} = (1+\rho)/(1-\rho)$$

Maximum uncertainties of the CF data are listed in Table 2 for the E4412A power sensor, and in Table 3 for the E4413A power sensor. The uncertainty analysis for the calibration of the sensors was done in accordance with the ISO/TAG4 Guide. The uncertainty data reported on the calibration certificate is the expanded uncertainty with 95% confidence level and a coverage factor of 2 .

Additionally, at frequencies other than the reference frequency, for measurements above 0 dBm include 0.5%/dB high power calibration factor uncertainty.

Table 2 **E4412A Calibration Factor Uncertainty at 1mW (0 dBm)**

Frequency	Uncertainty (%)^a
10 MHz	1.8
30 MHz	1.8
50 MHz	Reference
100 MHz	1.8
1.0 GHz	1.8
2.0 GHz	2.4
4.0 GHz	2.4
6.0 GHz	2.4
8.0 GHz	2.4
10.0 GHz	2.4
11.0 GHz	2.4
12.0 GHz	2.4
14.0 GHz	2.4
16.0 GHz	2.6
18.0 GHz	2.6

a. Specifications apply to instruments with serial prefix US3848 and above. For earlier instruments, refer to Appendix A.

General Information

Table 3

E4413A Calibration Factor Uncertainty at 1mW (0 dBm)

Frequency	Uncertainty (%) ^a
50 MHz	Reference
100 MHz	1.8
1.0 GHz	1.8
2.0 GHz	2.4
4.0 GHz	2.4
6.0 GHz	2.4
8.0 GHz	2.4
10.0 GHz	2.6
12.0 GHz	2.8
14.0 GHz	2.8
16.0 GHz	2.8
17.0 GHz	2.8
18.0 GHz	2.8
19.0 GHz	3.0
20.0 GHz	3.0
22.0 GHz	3.0
24.0 GHz	3.0
26.0 GHz	3.0
26.5 GHz	3.0

a. Specifications apply to instruments with serial prefix US3848 and above. For earlier instruments, refer to Appendix A.

Installation

Initial Inspection

Inspect the shipping container for damage. If the shipping container or packaging material is damaged, it should be kept until the contents of the shipment have been checked mechanically and electrically. If there is mechanical damage or if the instrument does not pass the performance tests, notify the nearest Agilent Technologies office. Keep the damaged shipping materials (if any) for inspection by the carrier and a Agilent Technologies representative.

Interconnections

Connect one end of the 11730A sensor cable to the E4412A or E4413A power sensor and connect the other end of the cable to the power meter's channel input. Allow a few seconds for the power meter to download the power sensor's calibration table before making a measurement.

Measurement connector (connects to DUT)

E4412A: Type-N (male)

E4413A: 3.5-mm (male)

A torque wrench should be used to tighten these connectors. Use a 3/4-inch open-end wrench and torque to 12 in-lb (135 Ncm) for the Type-N connector. Use a 20-mm open-end wrench and torque to 8 in-lb (90 Ncm) for the 3.5-mm connector.

Storage and Shipment

Environment

The instruments should be stored in a clean, dry environment. The following limitations apply to both storage and shipment:

Temperature	-55 to +75°C
Relative humidity	< 95% at 40°C
Altitude	< 15,240 metres (50,000 feet)

Original Packaging

Containers and materials identical to those used in factory packaging are available through Agilent Technologies offices. If the instrument is being returned to Agilent Technologies for servicing, attach a tag indicating the type of service required, return address, model number, and serial number. Also, mark the container **FRAGILE** to assure careful handling. In any correspondence, refer to the instrument by model number and serial number.

Operation

Operating Environment

The operating environment for the power sensor should be within the following limits:

Temperature	0° to 55°C
Relative humidity	< 95%
Altitude	< 4530 metres (15,000 feet)

Operating Precautions

WARNING:

BEFORE CONNECTING THE POWER SENSOR TO OTHER INSTRUMENTS, ensure that all instruments are connected to the protective (earth) ground. Any interruption of the protective earth grounding will cause a potential shock hazard that could result in personal injury and cause damage to the power sensor.

If the following energy and power levels are exceeded, the power meter system may be damaged.

- a Maximum Average Power: 200 mW (+23 dBm)
- b Maximum Peak Power: 200 mW (+23 dBm)

Maximum torque at the connector should not exceed 12 in-lb (135 Ncm) for the Type-N connector, or 8 in-lb (90 Ncm) for the 3.5-mm connector to avoid damage to the connector.

Connect the power sensor by turning only the hex nut portion of the connector. Damage can occur if torque is applied to the power sensor body.

The connector plastic insulator bead deteriorates when contacted by acetone, trichloroethylene, carbon tetrachloride, benzene, etc. Refer to Application Note 326, Principals of Microwave Connector Care (5954-1566) or Microwave Connector Care (08510-90064) for proper cleaning methods.

Operation

Power Meter Calibrations

Follow the calibration procedures given in your power meter manual.

Operating Instructions

The E4412A and E4413A power sensors are compatible **ONLY** with the newer E44XX-Series power meters. They are **NOT** compatible with the earlier 430-Series, E1416A, or 70100A power meters. To operate the power sensor, refer to the operating instructions in the *Agilent E44XX-Series Power Meter User's Guide*.

Performance Test

Standing Wave Ratio (SWR) and Reflection Coefficient (Rho) Performance Test

This section does not establish preset SWR test procedures since there are several test methods and different equipment available for testing the SWR or reflection coefficient. Therefore, the actual accuracy of the test equipment must be accounted for when measuring against instrument specifications to determine a pass or fail condition. The test system used must not exceed the system Rho uncertainties shown in Table 4 when testing the E4412A, or in Table 5 when testing the E4413A.

Table 4

Power Sensor SWR and Reflection Coefficient for the E4412A^a

Frequency	System Rho Uncertainty	Actual Measurement	Maximum Rho
10 MHz to <30 MHz	±0.010		0.099
30 MHz to <2 GHz	±0.010		0.070
2 GHz to <6 GHz	±0.010		0.078
6 GHz to <11 GHz	±0.010		0.091
11 GHz to 18 GHz	±0.010		0.119

a.Specifications apply to instruments with serial prefix US3848 and above. For earlier instruments, refer to Appendix A.

Table 5

Power Sensor SWR and Reflection Coefficient for the E4413A^a

Frequency	System Rho Uncertainty	Actual Measurement	Maximum Rho
50 MHz to <100 MHz	± 0.010		0.095
100 MHz to <8 GHz	± 0.010		0.087
8 GHz to <18 GHz	± 0.010		0.095
18 GHz to 26.5 GHz	± 0.015		0.115

a. Specifications apply to instruments with serial prefix US3848 and above. For earlier instruments, refer to Appendix A.

Replaceable Parts

Table 6 is a list of replaceable parts. Figure 3 is the illustrated parts breakdown (IPB) that identifies all of the replaceable parts. To order a part, quote the Agilent Technologies part number, specify the quantity required, and address the order to the nearest Agilent Technologies office.

NOTE:

Within the USA, it is better to order directly from the Agilent Parts Center in Roseville, California. Ask your nearest Agilent office for information and forms for the “Direct Mail Order System.” Also your nearest Agilent office can supply toll free telephone numbers for ordering parts and supplies.

Operation and Service Guide
Replaceable Parts

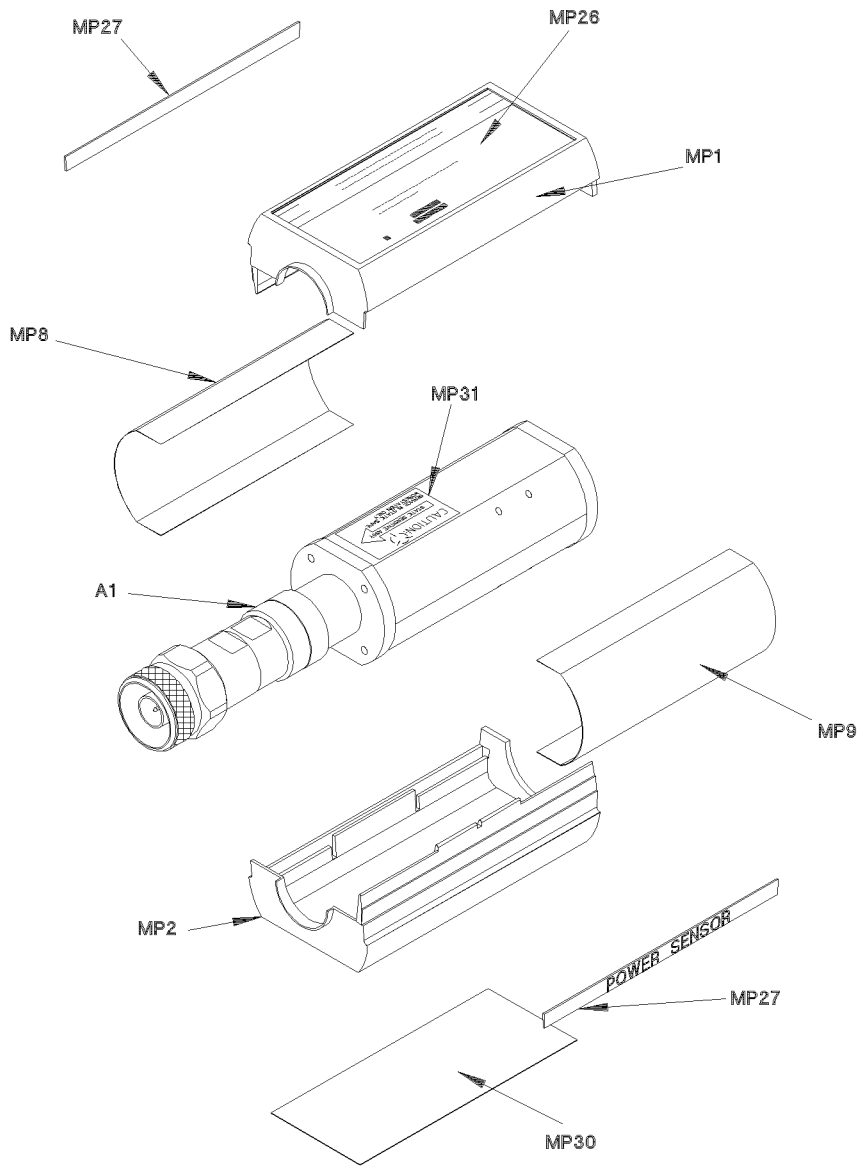

ss72a

Figure 3

Illustrated Parts Break down

Table 6 **Replaceable Parts**

Reference Designation	Part Number	Qty	Description
A1/A2 E4412A	E4412-60006	1	SENSOR MODULE (E4412A)
A1/A2 E4412A	E4412-69006	1	RESTORED SENSOR MODULE (E4412A)
A1/A2 E4413A	E4413-60003	1	SENSOR MODULE (E4413A)
A1/A2 E4413A	E4413-69003	1	RESTORED SENSOR MODULE (E4413A)
	08485-60005	1	ADAPTOR, 3.5-mm to Type-N
			CHASSIS PARTS
MP1	5041-9160	2	SHELL-PLASTIC
MP2	5041-9160		SHELL-PLASTIC
MP3	08481-20011	2	CHASSIS
MP4	08481-20011		CHASSIS
MP8	08481-00002	2	SHIELD
MP9	08481-00002		SHIELD
MP26	E4412-80002	1	LABEL, ID E4412A
MP26	E4413-80003	1	LABEL, ID E4413A
MP27	7121-7389	2	LABEL, POWER SENSOR
MP30	7121-7388	1	LABEL, CAL/ESD
MP31	00346-80011	1	LABEL, CAUTION

Service

Service instructions consist of principles of operation, troubleshooting, and repairs.

Principles of Operation

The A1 Bulkhead assembly provides a 50 ohm load to the RF signal applied to the power sensor. A diode assembly in the bulkhead rectifies the applied RF to produce a dc voltage which varies with the RF power across the 50 ohm load. Thus the voltage varies with the RF power dissipated in the load. With maximum specified RF power (100 mW) the dc voltage is approximately 1V.

The low-level dc voltage from the bulkhead assembly must be amplified before it can be transferred on standard cables to the power meter. The amplification is provided by an input amplifier assembly which consists of a chopper (sampling gate) and an input amplifier. The chopper circuit converts the dc voltage to an ac voltage. To do this, the chopper uses two field effect transistors (FETs), A2Q1 and A2Q2, controlled by a 440 Hz square wave generated by the power meter. The amplitude of the sampling gate output (drain of A2Q1, source of A2Q2) is a 440 Hz square wave which varies with the RF power input. The 440 Hz ac output is applied to the input amplifier A2Q3 which provides the input to the first amplifier stage in the power meter.

The E44XX-Series power meter automatically detects when an E44XX-Series power sensor is connected and downloads the correction data from the sensor's EEPROM. This configures the power meter to operate over the +20 dBm to -70 dBm power range with that particular sensor's unique correction data applied.

Troubleshooting

Troubleshooting information is intended to first isolate the power sensor, the cable, or the power meter as the defective component. When the power sensor is isolated, a "Restored Sensor Module" must be used for repair. See Table 6.

If error message **241** or **310** is indicated on the power meter, suspect a failed power sensor. If no error message is displayed, but a problem occurs when making a measurement, try replacing the cable from the power meter to the power sensor. If the problem still exists, try using a different power sensor to determine if the problem is in the power meter or in the power sensor.

CAUTION:

Electrostatic discharge will render the power sensor inoperative. Do not, under any circumstances, open the power sensor unless you and the power sensor are in a static free environment.

Repair of Defective Sensor

There are no serviceable parts inside the E44XX-Series sensors. If the sensor is defective, replace the entire “module” with the appropriate “Restored Sensor Module.” See Table 6.

Cleaning

Cleaning Solutions

Keeping in mind its flammable nature; a solution of pure isopropyl or ethyl alcohol can be used to clean the connector.

Connector Cleaning

CAUTION:

The RF connector beads deteriorate when contacted by hydrocarbon compounds such as acetone, trichloroethylene, carbon tetrachloride, and benzene.

CAUTION:

Clean the connector only at a static free workstation. Electrostatic discharge to the center pin of the connector will render the power sensor inoperative.

Clean the connector face using a cotton swab dipped in isopropyl alcohol. If the swab is too big use a round wooden toothpick wrapped in a lint free cotton cloth dipped in isopropyl alcohol. Refer to Agilent Application Note 326, Principals of Microwave Connector Care (5954-1566) or Microwave Connector Care (08510-90064) for proper cleaning methods.

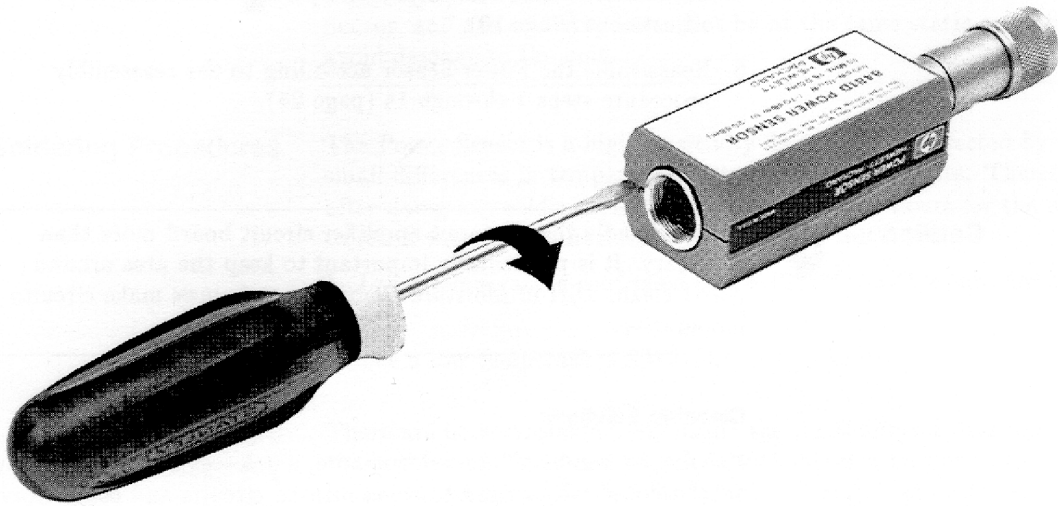

ss75a

Figure 4

Removing Power Sensor Shell

Disassembly Procedure

Disassemble the power sensor by performing the following steps:

CAUTION:

Disassemble the power sensor only in a static free workstation. Electrostatic discharge will render the power sensor inoperative.

- 1 At the rear of the power sensor, insert the blade of a screwdriver between the plastic shells (Figure 4). To prevent damage to the plastic shells use a screwdriver blade as wide as the slot between the two shells.
- 2 Pry alternately at both sides of the connector J1 until the plastic shells are apart. Remove the shells and the magnetic shields.

Reassembly Procedure

- 1 Replace the magnetic shields and the plastic shells as shown in Figure 3. Snap the plastic shells together.

Agilent Sales and Service Offices

Table 7

UNITED STATES (tel) 1 800 829 4444
EUROPE (tel) (31 20) 547-2323 (fax) (31 20) 547-2390
CANADA (tel) 1 877 894 4414 (fax) (905) 206 4120
LATIN AMERICA (tel) (305) 269 7500 (fax) (305) 269 7599
JAPAN (tel) (81) 426 56 7832 (fax) (81) 426 56 7840
AUSTRALIA (tel) 1 800 629 485 (fax) (61 3) 9210 5947
NEW ZEALAND (tel) 0 800 738 378 (fax) 64 4 495 8950
ASIA PACIFIC (tel) (852) 3197 7777 (fax) (852) 2506 9284

Online Assistance: www.agilent.com/find/assist

Appendix

The following specifications apply to E4412A and E4413A sensors (formerly ECP-E18A and ECP-E26A, respectively) with a serial prefix below US3848.

Table 8 E4412A and E4413A Specifications (Serial Prefixes Below US3848)

	Limits	Comments
Frequency Range	E4412A: 10 MHz to 18 GHz E4413A: 50 MHz to 26.5 GHz	
Power Range	-70 dBm to +20 dBm (100 pW to 100 mW)	
Impedance	50 ohm	nominal
Connector Type	E4412A: Type-N (male) E4413A: 3.5-mm (male)	
Maximum Standing Wave Ratio (SWR) and Reflection Coefficient (Rho)	SWR Rho	Return Loss (dB)
E4412A		
10 MHz to 30 MHz	1.34 0.145	16.8
30 MHz to 10 GHz	1.22 0.100	20.0
10 GHz to 18 GHz	1.27 0.120	18.4
E4413A		
50 MHz to 2 GHz	1.25 0.110	19.2
2 GHz to 18 GHz	1.21 0.095	20.5
18 GHz to 26.5 GHz	1.26 0.115	18.8
Maximum Power	200 mW peak (+23 dBm) 200 mW average (+23 dBm)	
Zero Set	±50 pW	

Table 8 E4412A and E4413A Specifications (Serial Prefixes Below US3848)

	Limits		Comments
Power Linearity^a	25 ± 5°C	0 to 55°C	(After calibration at 0 dBm at ambient temperature)
100 pW to 10 mW	±4%	±8%	-70 dBm to +10 dBm
10 mW to 100 mW	±5.5%	±11%	+10 dBm to +20 dBm
Operating Temperature	0 to 55°C		
Net Weight			
E4412A	0.47 kg (1.04 lb)		
E4413A	0.45 kg (1.00 lb)		
Dimensions			
E4412A	Length: 130 mm (5.1 in)		Same for both models Same for both models
E4413A	Length: 102 mm (4.0 in)		
	Width: 38 mm (1.5 in)		
	Height: 30 mm (1.2 in)		

a. Limits are in percent of power in Watts. See Figure 2 for relative power measurement.

Table 9

**E4412A Calibration Factor Uncertainty at 1mW (0 dBm)
(Serial Prefixes Below US3848)**

Frequency	Uncertainty
10 MHz	2.7%
30 MHz	2.7%
50 MHz	Reference
100 MHz	2.7%
1.0 GHz	2.7%
2.0 GHz	3.1%
4.0 GHz	3.1%
6.0 GHz	3.1%
8.0 GHz	3.1%
10.0 GHz	3.1%
11.0 GHz	3.1%
12.0 GHz	3.3%
14.0 GHz	3.3%
16.0 GHz	3.3%
18.0 GHz	3.3%

Table 10 **E4413A Calibration Factor Uncertainty at 1mW (0 dBm)**
(Serial Prefixes Below US3848)

Frequency	Uncertainty
50 MHz	Reference
100 MHz	2.7%
1.0 GHz	2.7%
2.0 GHz	3.1%
4.0 GHz	3.1%
6.0 GHz	3.1%
8.0 GHz	3.1%
10.0 GHz	3.1%
12.0 GHz	3.3%
14.0 GHz	3.3%
16.0 GHz	3.3%
17.0 GHz	3.3%
18.0 GHz	3.5%
20.0 GHz	3.5%
22.0 GHz	3.5%
24.0 GHz	3.5%
26.0 GHz	3.5%
26.5 GHz	3.5%